

# DTE Series EtherCAT Slave Module MANUAL

# Chapter 1: Product Introduction



## 1.1 Hardware Specifications

### Analog Output

- 1 channel 0-5V analog output

### Quadrature Encoder Input

- 1 set of Quadrature Encoder Input
- Max. input frequency: 32MHz
- Format: A-B phase with Index

### Digital Input and Output

- 7 general inputs and 7 general outputs

### Reset

- 1 Reset input

### Power Requirements

- DC input range: DC 24V  $\pm$ 2V with over-voltage and reversed-voltage protection

Drive model	DTE-015-D	DTE-030-D	DTE-040-D	DTE-080-D	DTE-120-D
Rated voltage	DC24V	DC24V	DC24V	DC24V	DC24V
Rated power	15W	30W	40W	80W	120W
Rated current	0.95 A	1.6 A	1.9A	3.4A	5A
Rated torque	0.5kg-cm	1kg-cm	1.3kg-cm	2kg-cm	2.5kg-cm

## EtherCAT Section

- Data transfer medium: Ethernet cable (CAT5e), shield type: S/STP or S/UTP
- Ethernet interface: 2x RJ-45
- Data transfer rate: 100Mbps, full duplex
- Protocol: EtherCAT
- Device profile: CiA 402

## Size

- Dimension (mm): 40(W) x 138(L) x 70(H)

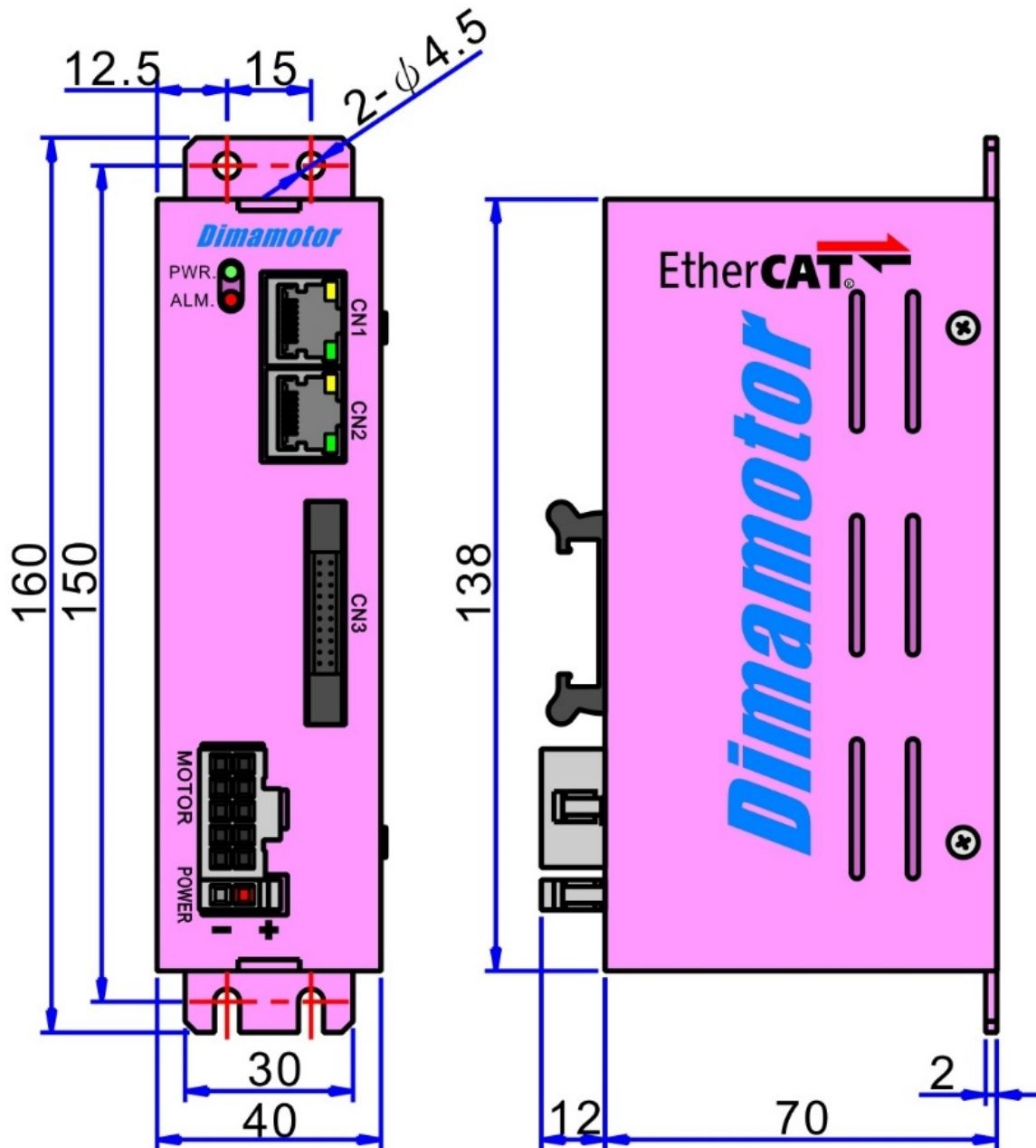

# Chapter 2: Connector Pinout Assignments and Wiring Diagrams

## 2.1 Before You Begin

- Ensure you have a stable, clean working environment.
- Before working on any components, make sure that the power is off.
- Ground yourself before touching any components.
- Static electricity can damage many of the electronic components.

## 2.2 Locations of the Connectors and LEDs



## 2.3 LED Indicators

PER	Power LED	
	ON	Power supply connect to 24 VDC
	OFF	Power supply doesn't connect to 24 VDC

ALARM	ON	ALARM ON
	OFF	ALARM INVALID

## 2.4 Power Supply Connector

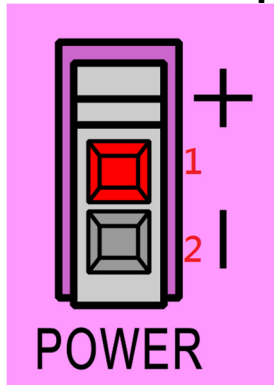

PIN	NAME	TYPE	Definition
1	+24V	PWR	DC Power Supply
2	GND	PWR	DC 0V

## 2.5 MOTOR Connector



## 2.6 Digital Input and Output

### 2.6.1 Input

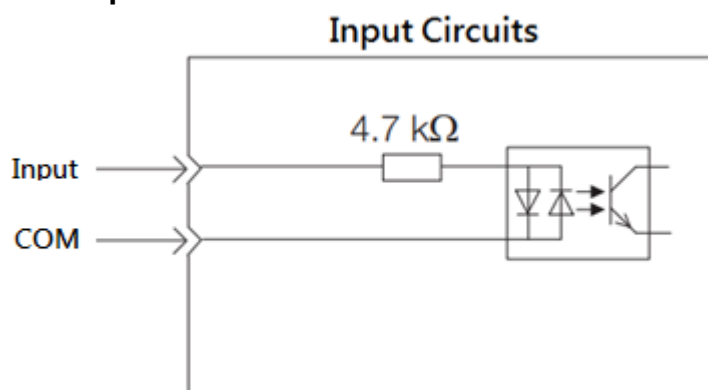

- Isolated Input with 3750 Vrms
- Current range: 1mA~50mA

### 2.6.1.1 General purpose input (CN3)

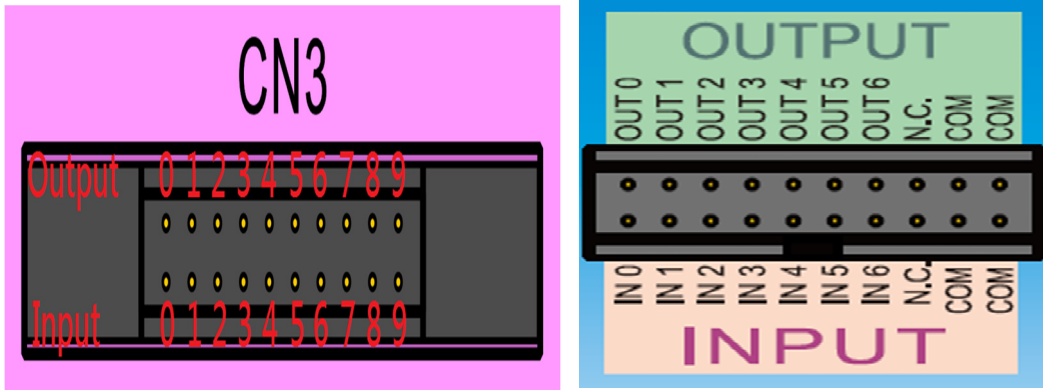

PIN	NAME	TYPE	Definition
0	IN0	IN	General purpose input 0
1	IN1	IN	General purpose input 1
2	IN2	IN	General purpose input 2
3	IN3	IN	General purpose input 3
4	IN4	IN	General purpose input 4
5	IN5	IN	General purpose input 5
6	IN6	IN	General purpose input 6
7	IN7	IN	NC
8、9	COM	PWR	0V or 5V or 24 V

### 2.6.2 Output

#### Output Circuits

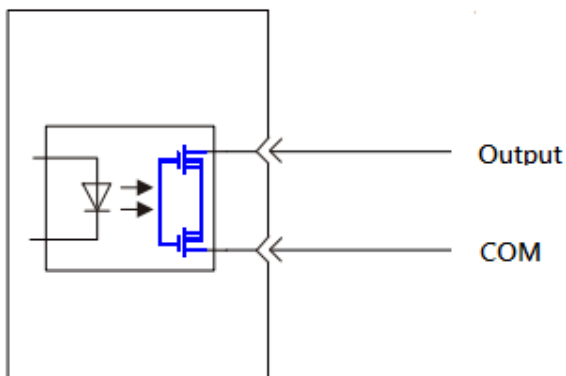

- Isolated output with 1500 Vrms
- Single max current : 2A
- Voltage range: 5~60V

### 2.6.2.1 General purpose output (CN3)

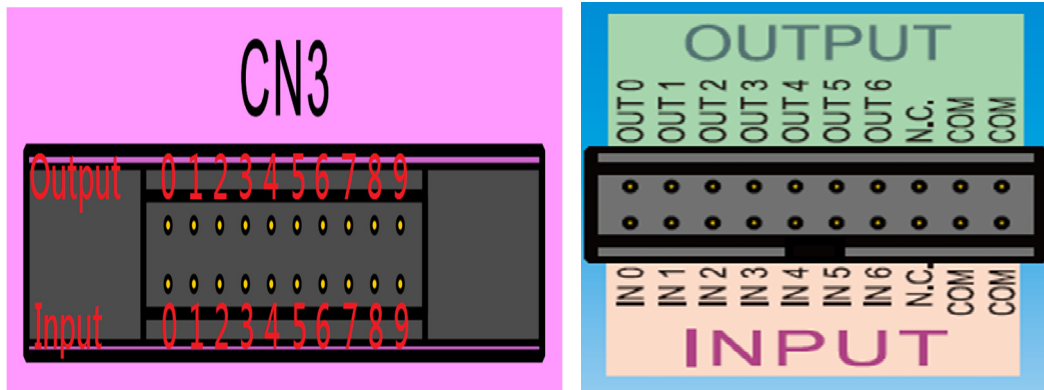

PIN	NAME	TYPE	Definition
0	OUT0	OUT	General purpose output 0
1	OUT1	OUT	General purpose output 1
2	OUT2	OUT	General purpose output 2
3	OUT3	OUT	General purpose output 3
4	OUT4	OUT	General purpose output 4
5	OUT5	OUT	General purpose output 5
6	OUT6	OUT	General purpose output 6
7	OUT7	OUT	NC
8、9	COM	PWR	0V

## 2.7 Product system block diagram

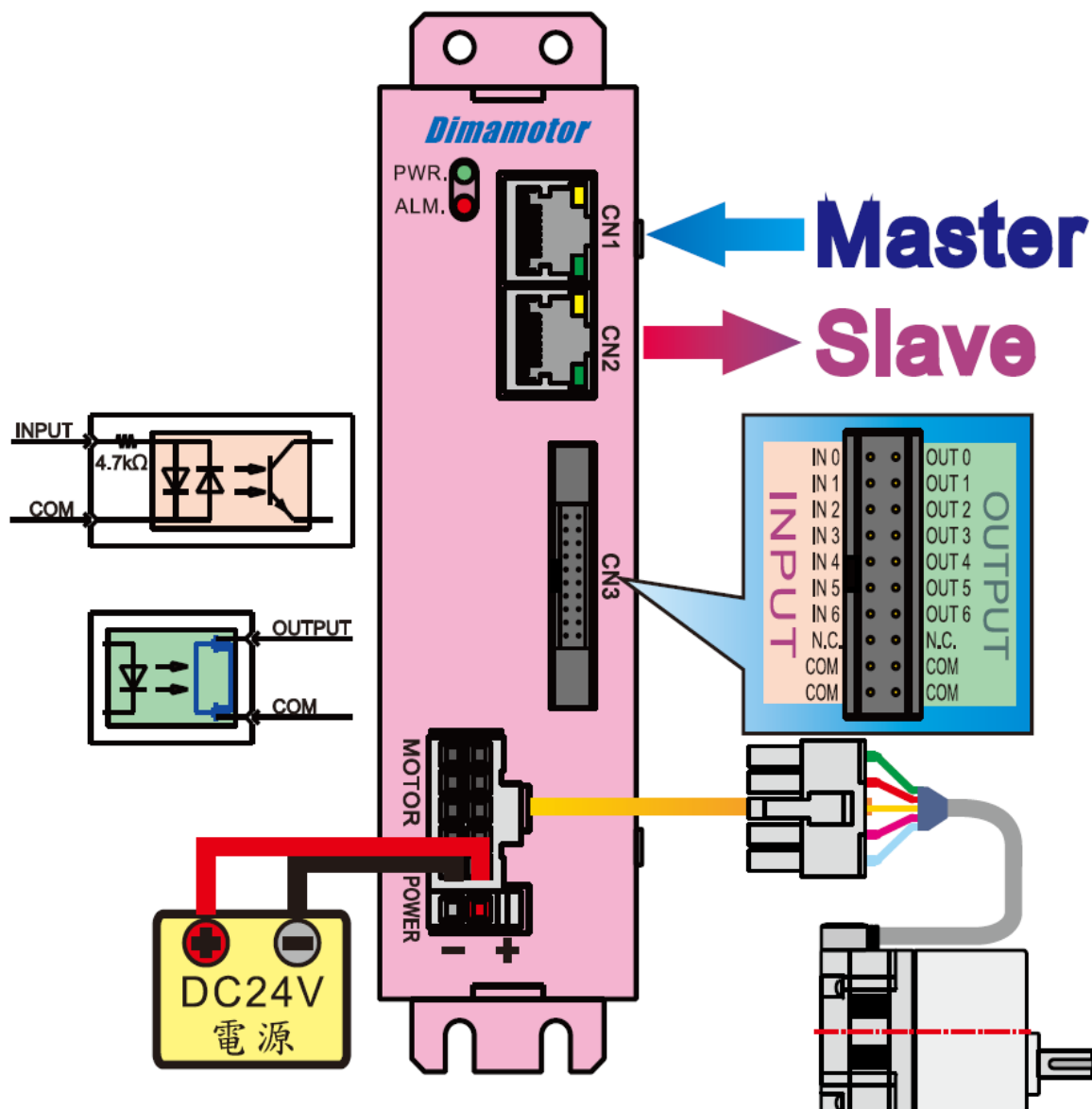

## 2.8 Product related parts

2.8.1 : DC power cable : DPL-030(30cm)x 1 pcs

2.8.2 : I/O connect : IOC-1 x 1 pcs

2.8.3 : motor connect : KDL-03 x 1 set

# Chapter 3: Operation

## 3.1 EtherCAT Slave Information (ESI)

According to EtherCAT standard document ETG.2000, every EtherCAT slave must be delivered an ESI file (a XML format to describe EtherCAT slave information) for the EtherCAT Master. The ESI file contains the necessary settings for the communication.



# Chapter 4: Object Dictionary

## 4.1 Architecture of Object Dictionary

Index (Hex)	Meaning
0x1000~0x1FFF	CoE communication objects
0x2000~0x5FFF	Manufacturer Specific Objects
0x6000~0x7FFF	CANOpen CiA 402 Profile Specific Objects

## 4.2 Object Type and Attributes

Code	C/C++ type	Description	Size (byte)	Range
USINT	uint8_t	unsigned byte	1	0~255
UINT	uint16_t	unsigned short integer	2	0~65535
UDINT	uint32_t	unsigned long integer	4	0~4294967295
SINT	int8_t	signed byte	1	-128~127
INT	int16_t	signed short integer	2	-32768~32767
DINT	int32_t	signed long integer	4	-2147483648~2147483647
STRING	-	string value	-	-

Attribute	Description
RO	This object is only for read.
WO	This object is only for write.
RW	This object is for read and write.

### 4.3 Object Dictionary List

Object Dictionaries		Refer to
General Objects	Device Type (1000h)	4.4
	Manufacturer Device Name (1008h)	4.4
	Manufacturer Hardware Version (1009h)	4.4
	Manufacturer Software Version (100Ah)	4.4
	Identity Object (1018h)	4.4
PDO Mapping Objects	Receive PDO Mapping (1600h to 1602h)	4.4
	Transmit PDO Mapping (1A00h to 1A02h)	4.4
Sync Manager Communication Objects	Sync Manager Communication Type (1C00h)	4.4
	Sync Manager Synchronization (1C32h, 1C33h)	4.4
	Sync Error Setting (10F1h)	4.4
Manufacturer Specific Objects		
	Acceleration Divisor(2001h)	4.5
	Encoder Setting(2004h)	4.5
	Alarm LED(2021h)	4.5
	DAC Parameter 1(2022h)	4.5
	DAC Parameter 2(2023h)	4.5
	Speed Out(2024h)	4.5
PPR(2025h)	4.5	
Device Control	Controlword (6040h)	4.6
	Statusword (6041h)	4.6
	Quick Stop Option Code (605Ah)	4.6
	Shutdown Option Code (605Bh)	4.6
	Disable Operation Option Code (605Ch)	4.6
	Halt Option Code (605Dh)	4.6
	Fault Reaction Option Code (605Eh)	4.6
	Modes of Operation (6060h)	4.6
	Modes of Operation Display (6061h)	4.6
	Supported Drive Modes (6502h)	4.6
Profile Velocity Mode/ Cyclic Synchronous Velocity Mode	Position Actual Value (6064h)	4.6
	Velocity Actual Value (606Ch)	4.6
	Max. Profile Velocity (607Fh)	4.6
	Profile Acceleration (6083h)	4.6
	Profile Deceleration (6084h)	4.6
	Quick Stop Deceleration (6085h)	4.6
Target Velocity (60FFh)	4.6	
Interpolation time period (60C2h)	4.6	
Digital Inputs/Outputs	Digital Inputs (60FDh)	4.6
	Digital Outputs (60FEh)	4.6

## 4.4 CoE Communication Objects (0x1000~0x1FFF)

### Device type

Index	Sub	Name	Data Type	Access	PDO Mapping	Default Value
0x1000	00	Device type	UDINT	RO	N	0x40192

- Bit0~15: 0x192 (DS402 device)
- Bit16~23: 0x04 (Stepper Drive)

### Device name

Index	Sub	Name	Data Type	Access	PDO Mapping	Default Value
0x1008	00	Device name	STRING	RO	N	DIMADT

### Hardware version

Index	Sub	Name	Data Type	Access	PDO Mapping	Default Value
0x1009	00	Hardware version	STRING	RO	N	0

### Software version

Index	Sub	Name	Data Type	Access	PDO Mapping	Default Value
0x100a	00	Software version	STRING	RO	N	0

### Identity

Index	Sub	Name	Data Type	Access	PDO Mapping	Default Value
0x1018	00	Number of entries	USINT	RO	N	4
	01	Vendor ID	UDINT	RO	N	0x00000BC4
	02	Product code	UDINT	RO	N	DIMADT
	03	Revision	UDINT	RO	N	0
	04	Serial number	UDINT	RO	N	0

0x1018:02 Product code:

### Error Settings

Index	Sub	Name	Data Type	Access	PDO Mapping	Default Value
0x10F1	00	Number of entries	USINT	RO	N	2
	01	Local Error Reaction	Reserved	-	-	-
	02	Sync Error Counter Limit	UINT	RW	N	4

#### • 0x10F1:02 Sync Error Counter Limit

In DC mode, if the local error counter reaches the limit, the EtherCAT state machine will change to SAFEOP state. The local error counter is set to 0 when the state machine changing to OP state. If the slave miss an SM2 event between two Sync0 events, the local error counter increases by 3; otherwise, the counter decreases by 1.

### CSV RxDPO

Index	Sub	Name	Data Type	Access	PDO Mapping	Default Value
0x1602	00	Number of objects in this PDO	USINT	RO	N	3
	01	Mapping entry 1	UDINT	RO	N	0x604000 10
	02	Mapping entry 2	UDINT	RO	N	0x60FF0 020
	03	Mapping entry 3	UDINT	RO	N	0x60FE0 120

- 0x1602:01 The 1st RxDPO entry: 0x6040:00 (Control word)
- 0x1602:02 The 2nd RxDPO entry: 0x60FF:00 (Target velocity)
- 0x1602:03 The 3rd RxDPO entry: 0x60FE:01 (Digital outputs of channel 0 to 10)

### CST/PT RxPDO

Index	Sub	Name	Data Type	Access	PDO Mapping	Default Value
0x1603	00	Number of objects in this PDO	USINT	RO	N	3
	01	Mapping entry 1	UDINT	RO	N	0x60400010
	02	Mapping entry 2	UDINT	RO	N	0x60710010
	03	Mapping entry 3	UDINT	RO	N	0x60FE0120

- 0x1603:01 The 1st RxPDO entry: 0x6040:00 (Control word)
- 0x1603:02 The 2nd RxPDO entry: 0x6071:00 (Target torque)
- 0x1603:03 The 3rd RxPDO entry: 0x60FE:01 (Digital outputs of channel 0 to 6)

### CSV TxPDO

Index	Sub	Name	Data Type	Access	PDO Mapping	Default Value
0x1a02	00	Number of objects in this PDO	USINT	RO	N	3
	01	Mapping entry 1	UDINT	RO	N	0x60410010
	02	Mapping entry 2	UDINT	RO	N	0x60640020
	03	Mapping entry 3	UDINT	RO	N	0x60FD0020

- 0x1A02:01 The 1st TxPDO entry: 0x6041:00 (Status word)
- 0x1A02:02 The 2nd TxPDO entry: 0x6064:00 (Target position)
- 0x1A02:03 The 3rd TxPDO entry: 0x60FD:00 (Digital inputs of channel 0 to 6)

### Sync Manager Type

Index	Sub	Name	Data Type	Access	PDO Mapping	Default Value
0x1C00	00	Number of used Sync Manager channels	USINT	RO	N	4
	01	Communication type sync manager 0	USINT	RO	N	1
	02	Communication type sync manager 1	USINT	RO	N	2
	03	Communication type sync manager 2	USINT	RO	N	3
	04	Communication type sync manager 3	USINT	RO	N	4

- 0x1C00:01 Communication type of SM0: 1 (mailbox out)
- 0x1C00:02 Communication type of SM1: 2 (mailbox in)
- 0x1C00:03 Communication type of SM2: 3 (process data out)
- 0x1C00:04 Communication type of SM3: 4 (process data in)

### RxPDO assign

Index	Sub	Name	Data Type	Access	PDO Mapping	Default Value
0x1C12	00	Number of assigned PDOs	USINT	RW*	N	1
	01	PDO Mapping object index of assigned RxPDO	UINT	RW*	N	0x1602

\*Writable in only pre-operation state

- 0x1C12:00 Number of RxPDO: 1
- 0x1C12:01 1st RxPDO:
  - 0x1602 for CSV/PV mode.
  - 0x1603 for CST/PT mode.

### TxPDO assign

Index	Sub	Name	Data Type	Access	PDO Mapping	Default Value
0x1C13	00	Number of assigned PDOs	USINT	RW*	N	1
	01	PDO Mapping object index of assigned TxPDO	UINT	RW*	N	0x1A02

\*Writable in only pre-operation state

- 0x1C13:00 Number of TxPDO: 1
- 0x1C13:01 1st TxPDO: 0x1A02 for CSV mode.

### SM output parameter

Index	Sub	Name	Data Type	Access	PDO Mapping	Default Value
0x1C32	00	Number of Synchronization Parameters	USINT	RO	N	32
	01	Synchronization Type	UINT	RO	N	0
	02	Cycle Time	UDINT	RO	N	0
	03	Reserved	-	-	-	-
	04	Reserved	-	-	-	-
	05	Minimum Cycle Time	UDINT	RO	N	250000
	06	Reserved	-	-	-	-
	07	Reserved	-	-	-	-
	08	Reserved	-	-	-	-
	09	Delay Time	UDINT	RO	N	0
	0a	Sync0 Cycle Time	UDINT	RO	N	0
	0b	SM-Event Missed	UINT	RO	N	0

	0c	Reserved	-	-	-	-
	0d~1f	Reserved	-	-	-	-
	20	Sync Error	BOOL	RO	N	0

- 0x1C32:01 Synchronization Type: 0 for free-run mode, 1 for SM-sync mode, or 2 for DC-sync mode.
- 0x1C32:02 Cycle Time: Time between Sync0 events [ns]
- 0x1C32:05 Minimum Cycle Time: 250000 [ns]
- 0x1C32:0B SM-Event Missed: Referred to object 0x10F1
- 0x1C32:20 Sync Error: 1 for sync error occurs.

### SM input parameter

Index	Sub	Name	Data Type	Access	PDO Mapping	Default Value
0x1C33	00	Number of Synchronization Parameters	uint8	RO	N	32
	01	Synchronization Type	UINT	RO	N	0
	02	Cycle Time	UDINT	RO	N	0
	03	Shift time	Reserved	-	-	-
	04	Synchronization Types supported	Reserved	-	-	-
	05	Minimum Cycle Time	UDINT	RO	N	250000
	06	Calc and Copy Time	Reserved	-	-	-
	07	Reserved	Reserved	-	-	-
	08	Get Cycle Time	uint16	RO	N	0
	09	Delay Time	UDINT	RO	N	0
	0a	Sync0 Cycle Time	UDINT	RO	N	0



	0b	SM-Event Missed	UINT	RO	N	0
	0c	Cycle Time Too Small	UINT	RO	N	0
	0d	Shift Time Too Short	Reserved	-	-	-
	0e~1f	-	Reserved	-	-	-
	20	Sync Error	BOOL	RO	N	0

- 0x1C33:01 Synchronization Type: 0 for free-run mode, 1 for SM-sync mode, or 2 for DC-sync mode.
- 0x1C33:02 Cycle Time: Time between Sync0 events [ns]
- 0x1C33:05 Minimum Cycle Time: 250000 [ns]
- 0x1C33:0B SM-Event Missed: Referred to object 0x10F1
- 0x1C33:20 Sync Error: 1 for sync error occurs.

## 4.5 Manufacturer Specific Objects (0x2000~0x2FFF)

### Acceleration Divisor

Index	Sub	Name	Data Type	Access	PDO Mapping	Default Value
0x2001	00	Acceleration Divisor	UDINT	RW	N	1000

- 0x2001:00 Acceleration Divisor: 1 to 0xFFFFFFFF

The divisor of profile acceleration, homing acceleration, and quick stop acceleration.

Note: This object is loaded from and written to data flash.

### Alarm LED

Index	Sub	Name	Data Type	Access	PDO Mapping	Default Value
0x2021	00	Alarm LED	UDINT	RO	N	0

- 0x2021:00 Alarm LED: The latest error of the drive. The following table shows possible conditions.

status	Number of flashes	Fault condition	Troubleshooting method
Overcurrent protection	2	When the load current exceeds the rated current. (15W, 30W after 3 seconds) (40W or more after 5 seconds)	Please ensure that the driver is used under the condition of not exceeding the rated load.
Under-phase protection	3	The motor running interruption line or the motor line is not connected when starting, resulting in abnormal motor output signal.	Check if the motor wire is disconnected or disconnected.
Low voltage protection	4	Input voltage is lower than rated voltage 15%.	Check whether the power supply of the device is too low.
Over-voltage protection	5	Input voltage is higher than rated voltage 30%.	Check whether the power supply of the device is too high.
Drive over temperature	7	Drive temperature exceeds 70-80°C.	Please consider whether the load exceeds the load of the drive. If this phenomenon often occurs under normal operation, it is recommended to replace the drive and motor with higher power according to the load.

### Speed out

Index	Sub	Name	Data Type	Access	PDO Mapping	Default Value
0x2024	00	Speed out	UDINT	RW	N	0

- 0x2024:00 Speed out: The speed of the motor. (unit: RPM)

### PPR

Index	Sub	Name	Data Type	Access	PDO Mapping	Default Value
0x2024	00	PPR	UDINT	RO	N	30

- 0x2024:00 PPR: Pulse per rotation for speed out signal.

DTE-015/030: 12

DTE-040/080: 30

DTE-120:24

### RUN/STOP Pin

Index	Sub	Name	Data Type	Access	PDO Mapping	Default Value
0x2026	00	RUN/STOP	USINT	RW	N	0

- 0x2026:00 RUN/STOP: 0 to 1.

0: Motor is Stop .

1: Motor is Run.

### DIR Pin

Index	Sub	Name	Data Type	Access	PDO Mapping	Default Value
0x2027	00	DIR	USINT	RW	N	0

- 0x2027:00 DIR: 0 to 1.

0: Motor CW .

1: Motor CCW.

### **BRAKE Pin**

Index	Sub	Name	Data Type	Access	PDO Mapping	Default Value
0x2028	00	BRAKE	USINT	RW	N	0

• 0x2028:00 BRAKE: 0 to 1.

0: The motor can run.

1: The motor cannot run.

## **4.6 CANOpen CiA 402 Profile Specific Objects(0x6000~0x7FFF)**

### **Control Word**

Index	Sub	Name	Data Type	Access	PDO Mapping	Default Value
0x6040	00	Control Word	UINT	RW	Y	0

• 0x6040:00 Control Word:

Bit 0 to 3 and bit 7: for the controlling command of the drive state

Command	bit 7	bit 3	bit 2	bit 1	bit 0
Shutdown	0	-	1	1	0
Switch on	0	0	1	1	1
Disable voltage	0	-	-	0	-
Quick stop	0	-	0	1	0
Disable operation	0	0	1	1	1
Enable operation	0	1	1	1	1
Fault reset	0→1	-	-	-	-

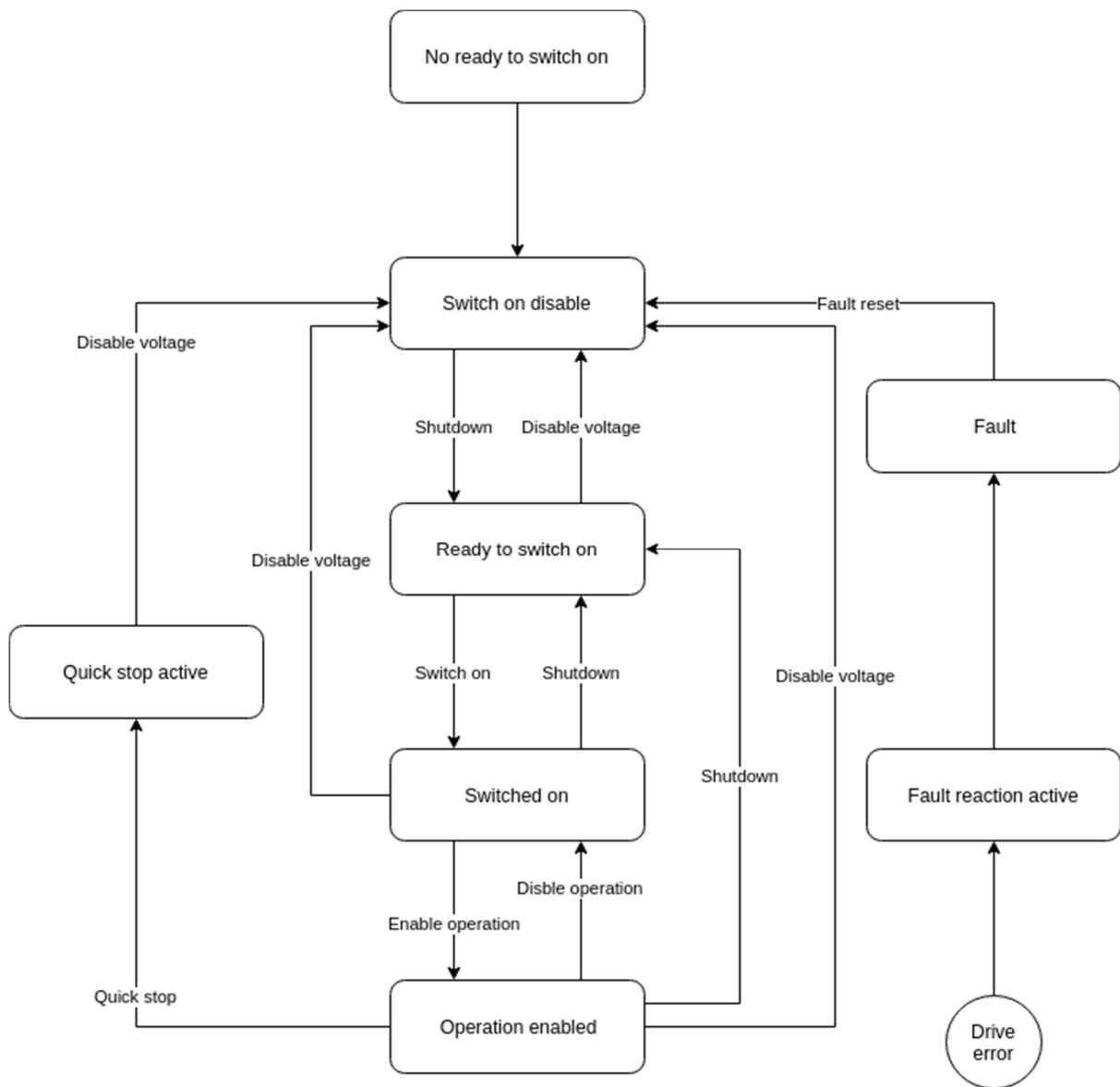

**DS402 state machine**

**Bit 4, 5, 6, 8 and 9: for the controlling of CSV/PV mode**

Bit	Function	Value	Description
4	-	0	Reserved
5	-	0	Reserved
6	-	0	Reserved
8	Halt	0	Do not halt CSV/PV procedure
		1	Halt CSV/PV procedure
9	-	0	Reserved

Bit 10 to 15: reserved. These bits should be set to 0s.

### Status Word

Index	Sub	Name	Data Type	Access	PDO Mapping	Default Value
0x6041	00	Status Word	UINT	RO	Y	*(See below)

• 0x6041:00 Status Word of Axis 0:

Bit 0 to 3 and bit 5 to 6: for the current state of the drive

Command	bit 6	bit 5	bit 3	bit 2	bit 1	bit 0
Not ready to switch on	0	0	0	0	0	0
Switch on disabled	1	0	0	0	0	0
Ready to switch on	0	1	0	0	0	1
Switched on	0	1	0	0	1	1
Operation enabled	0	1	0	1	1	1
Quick stop active	0	0	0	1	1	1
Fault reaction active	0	0	1	1	1	1
Fault	0	0	1	0	0	0

### Bit 10, 12 and 13: for Profile velocity mode

Bit	Status	Value	Description
10	Target reached	0	Halt (Bit 8 in Controlword) = 0: Target not reached Halt (Bit 8 in Controlword) = 1: Axis decelerates
		1	Halt (Bit 8 in Controlword) = 0: Target reached Halt (Bit 8 in Controlword) = 1: Velocity of axis is 0
12	-	-	Reserved
13	-	-	Reserved

### Quickstop Option Code

Index	Sub	Name	Data Type	Access	PDO Mapping	Default Value
0x605a	00	Quickstop Option Code	INT	RW	N	2

#### • 0x605A:00 Quickstop Option Code of Axis 0:

0: Disable driver function (turns the servo OFF)

1: Slow down on slow down ramp and stay in Operation Enabled. The slow down deceleration is defined as the following object.

- Profile Velocity mode, Cyclic Velocity mode: Object 0x6084

2: Slow down on quick stop ramp and stay in Operation Enabled.

Others: Reserve.

### Shutdown Option Code

Index	Sub	Name	Data Type	Access	PDO Mapping	Default Value
0x605b	00	Shutdown Option Code	INT	RW	N	0

#### • 0x605B:00 Shutdown Option Code:

0: Disable driver function (turns the servo OFF)

1: Slow down on slow down ramp and stay in Operation Enabled. The slow down deceleration is defined as the following object.

- Profile Velocity mode, Cyclic Velocity mode: Object 0x6084

Others: Reserved.

#### Disable Operation Option Code

Index	Sub	Name	Data Type	Access	PDO Mapping	Default Value
0x605c	00	Disable Operation Option Code	INT	RW	N	1

• 0x605C:00 Disable Operation Option Code:

0: Disable driver function (turns the servo OFF)

1: Slow down on slow down ramp and stay in Operation Enabled. The slow down deceleration is defined as the following object.

- Profile Velocity mode, Cyclic Velocity mode: Object 0x6084

Others: Reserved.

#### Halt Option Code

Index	Sub	Name	Data Type	Access	PDO Mapping	Default Value
0x605d	00	Halt Option Code	INT	RW	N	1

• 0x605D:00 Halt Option Code:

0: Disable driver function (turns the servo OFF)

1: Slow down on slow down ramp and stay in Operation Enabled. The slow down deceleration is defined as the following object.

- Profile Velocity mode, Cyclic Velocity mode: Object 0x6084

2: Slow down on quick stop ramp and stay in Operation Enabled.

Others: Reserved.

#### Fault Reaction Code

Index	Sub	Name	Data Type	Access	PDO Mapping	Default Value
0x605e	00	Fault Reaction Code	INT	RW	N	2

• 0x605E:00 Fault Reaction Code:

0: Disable driver function (turns the servo OFF)

1: Slow down on slow down ramp and stay in Operation Enabled. The slow down deceleration is defined as the following object.

- Profile Velocity mode, Cyclic Velocity mode: Object 0x6084

2: Slow down on quick stop ramp and stay in Operation Enabled.

Others: Reserved.



### Modes of Operation

Index	Sub	Name	Data Type	Access	PDO Mapping	Default Value
0x6060	00	Modes of Operation	SINT	RW	Y	0

• 0x6060:00 Modes of Operation:

4: Profile torque mode.

10: Cyclic synchronous velocity mode.

Others: Reserved.

### Modes of Operation Display

Index	Sub	Name	Data Type	Access	PDO Mapping	Default Value
0x6061	00	Modes of Operation Display	SINT	RO	Y	0

• 0x6061:00 Modes of Operation Display:

4: Profile torque mode.

10: Cyclic synchronous velocity mode.

Others: Reserved.

### Quick stop Deceleration

Index	Sub	Name	Data Type	Access	PDO Mapping	Default Value
0x6085	00	Quick stop Deceleration	DINT	RW	N	10

• 0x6085:00 Quick stop acceleration: 1 to 4294967295 [DAC unit/sec]

### Torque Slope

Index	Sub	Name	Data Type	Access	PDO Mapping	Default Value
0x6087	00	Torque Slope	UDINT	RW	N	100

• 0x6087:00 Target Torque: 0 to 4294967295.

The object sets the actual torque value slope in PT mode.

$$\text{Torque Slope} = \frac{\text{Object}[0x6087:00]}{\text{Object}[0x2001:00] \times (\text{cycle time})}$$

### Interpolation Time

Index	Sub	Name	Data Type	Access	PDO Mapping	Default Value
0x60c2	00	Highest sub-index supported	USINT	RO	N	2
	01	Interpolation period	USINT	RW	N	1
	02	Interpolation Index	SINT	RW	N	-3

• 0x60C2:01 Interpolation Period: 1 to 250

• 0x60C2:02 Interpolation Index: -6 to -3

$$\text{Interpolation time} = \text{Object}[0x60C2:01] \times 10^{\text{Object}[0x60C2:02]} [\text{sec}]$$

This object must be set properly in free run mode.

### Digital Inputs

Index	Sub	Name	Data Type	Access	PDO Mapping	Default Value
0x60fd	00	Digital Inputs	UDINT	RO	Y	-

• 0x60FD:00 Digital Inputs Channel 0 to 6:

Bit 0 to 6: digital inputs channel 0 to 6.

Bit 7 to 31: reserved.

### Digital Outputs

Index	Sub	Name	Data Type	Access	PDO Mapping	Default Value
0x60fe	00	Number of entries	USINT	RO	N	2
0x60fe	01	Physical Outputs	UDINT	RW	Y	0
0x60fe	02	Bit Mask	Reserve	-	-	-

• 0x60FE:01 Physical Outputs Channel 0 to 7:

Bit 0 to 10: digital outputs channel 0 to 7.

Bit 11 to 31: reserved.

• 0x60FE:02 Bit Mask: reserved.

### Target Torque

Index	Sub	Name	Data Type	Access	PDO Mapping	Default Value
0x6071	00	Target Torque	UINT	RW	Y	0

• 0x6071:00 Target Torque: 0 to 500.

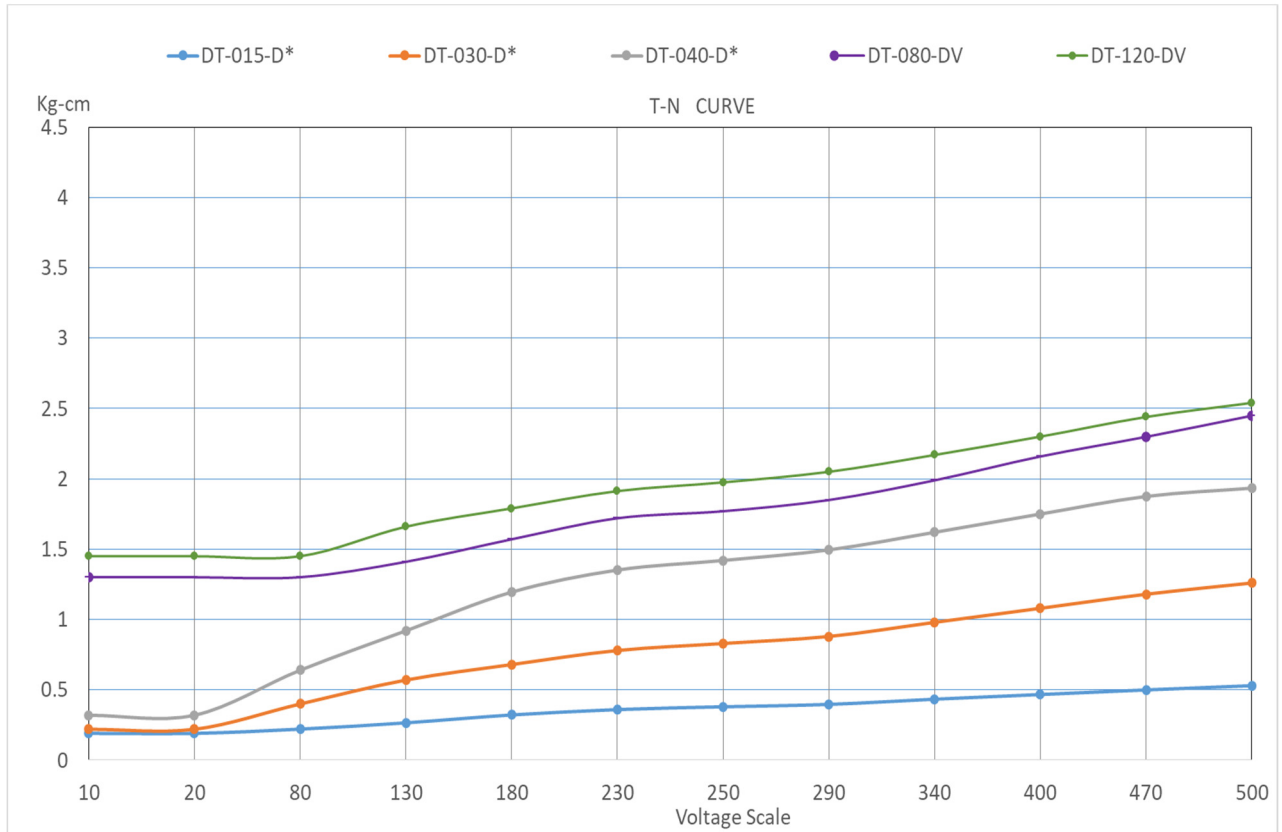

### Torque Actual Value

Index	Sub	Name	Data Type	Access	PDO Mapping	Default Value
0x6077	00	Torque Actual Value	UINT	RO	Y	0

- 0x6077:00 Target Torque: 0 to 500.

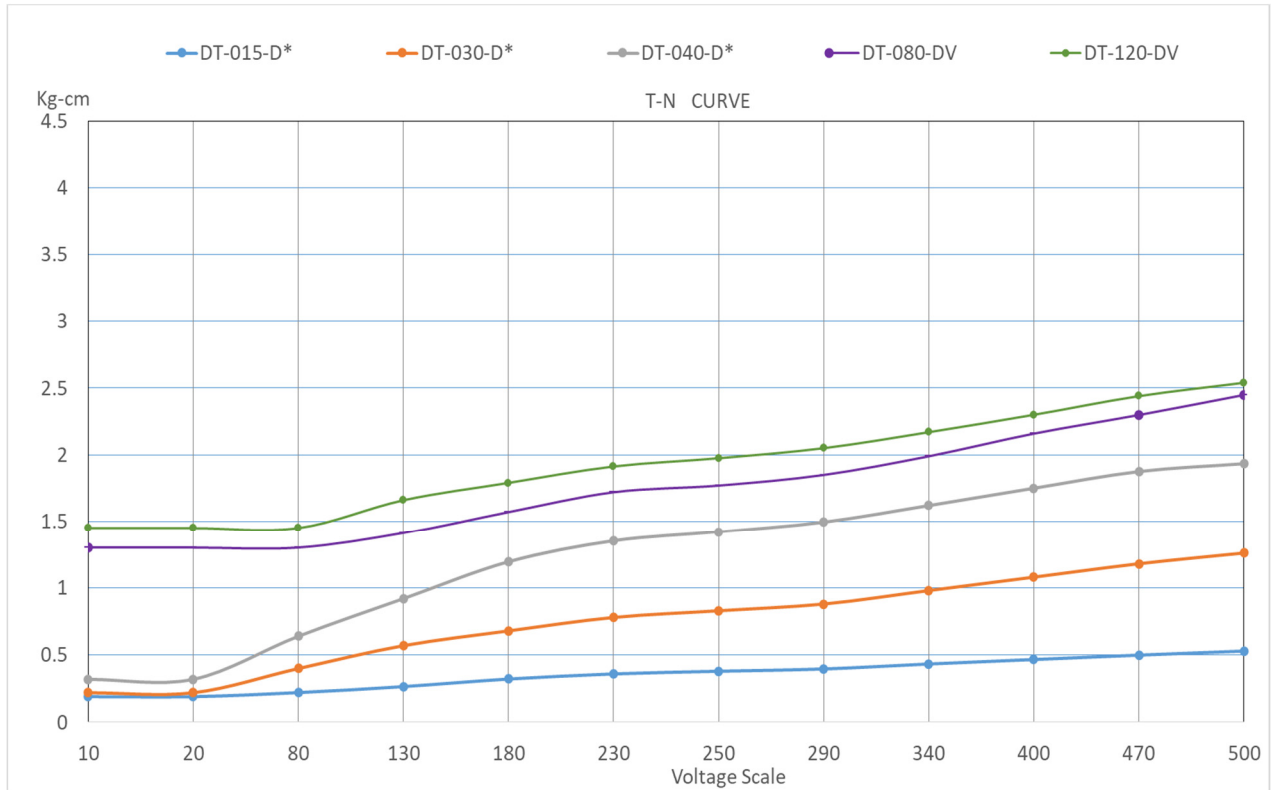

### Torque Slope

Index	Sub	Name	Data Type	Access	PDO Mapping	Default Value
0x6087	00	Torque Slope	UDINT	RO	Y	100

- 0x6087:00 Target Torque: 0 to 4294967295.

The object sets of torque output slope in PT mode.

$$\text{Torque Slope} = \frac{\text{Object}[0x6087:00]}{\text{Object}[0x2001:00]} \quad (\text{unit:0.2\%/s})$$

### Supported Drive Modes

Index	Sub	Name	Data Type	Access	PDO Mapping	Default Value
0x6502	00	Supported Drive Modes	UDINT	RO	N	0x30C

• 0x6502:00 Supported Drive Modes:

V/PT/CSV/CST modes are supported. (value=0x30C)