

Dimamotor

An efficient drive comes from an efficient motor

Dimensions (unit: mm)

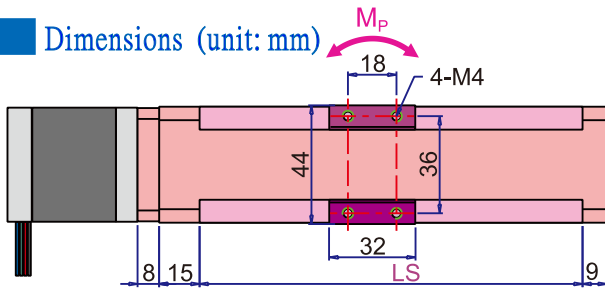

Allowable static torque of slider (N.m)		
M_R	M_P	M_Y
11.84	8.19	8.19

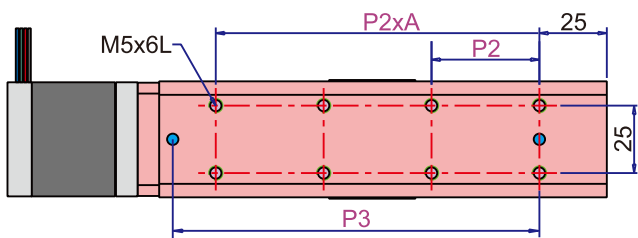
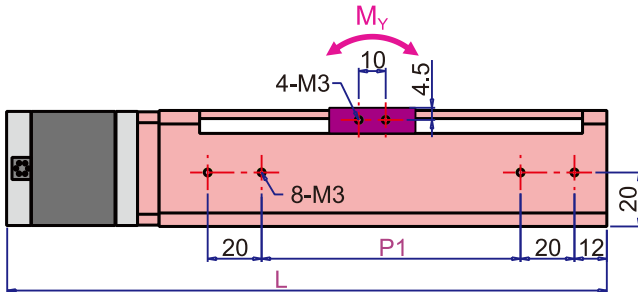

Product number	L	LS	P1	P2	P3	A
TN4P05-10A	237	142	96	40	129	3
TN4P05-15A	287	192	146	55	179	3
TN4P05-20A	327	232	186	65	219	3

System Wiring Diagram

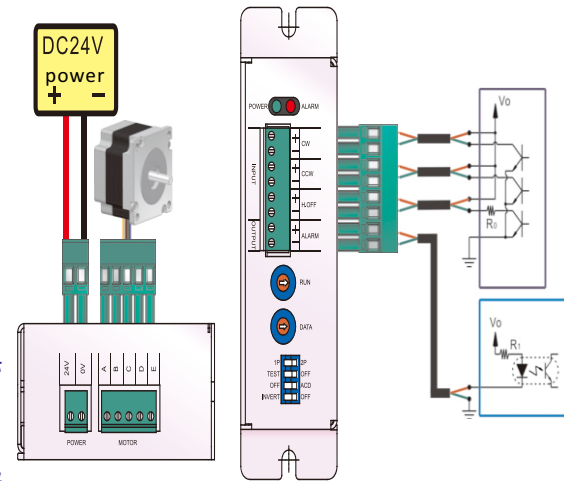

Drive Dimensions (unit: mm)

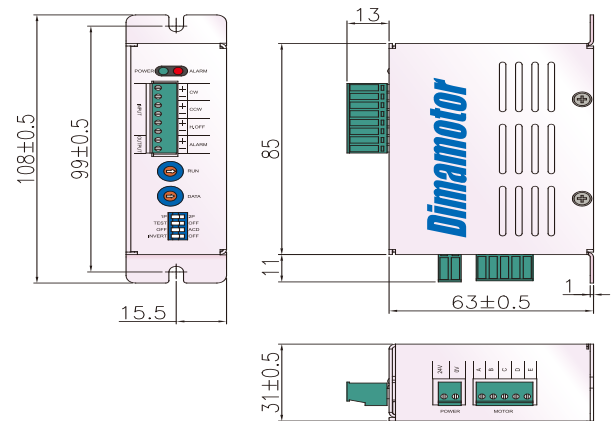

◆DS514HMD

Internal wiring diagram of stepper motor

Wiring comparison table of stepper motors of various brands					
Phase	A	B	C	D	E
Dimamotor	Blue	Red	Orange	Green	Black

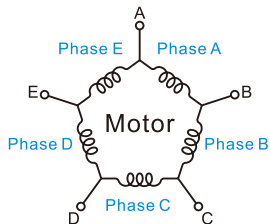

Dimamotor

An efficient drive comes from an efficient motor

Dima Motor Tech. Co., Ltd.

Head office: 5F-11, No. 22, Wuquan 2nd Road, Xinzhuang Dist, New Taipei City

Tel: (02) 2290-1968

Fax: (02) 2290-1969

Web: www.dimamotor.com.tw

E-mail: dimamotor.sales@gmail.com